

ABORT SWITCH

DESCRIPTION

The abort switch assembly, P/N 10-1639, consists of a momentary-contact, push button switch, normally-open contact block, normally-closed contact block, and stainless steel switch plate with adhesive label. The assembly can be recessed or surface mounted using a standard two-gang masonry box, minimum 2.5" (63.5 mm) deep (RACO 691), or equivalent. Masonry box not included.

FEATURES

- Stackable, screw-terminal, contact blocks
- Compatible with Fike suppression control panels
- Surface or flush mount
- Components mounted on a stainless steel face plate
- NFPA 72 initiating device

APPLICATIONS

The abort switch assembly is used to momentarily interrupt the release circuit signal when the control panel is in the alarm condition. As long as the push button is held in, the suppression system will not release unless it is overridden by a manual release input. Upon release of the abort push button, the release circuit is activated, unless the control panel has been reset to the non-alarm condition.

Operation of the control unit during abort activation varies depending upon panel programming. Refer to the associated control unit manual for detailed description of available abort operating modes (types).

SPECIFICATIONS

Weight: 0.45 lb (204 grams)
 Operating Temperature: 0° to 49°C (32° to 120°F)
 Wire Size: Min. 1 x 22 AWG, Max. 2 x 14 AWG or 1 x 12 AWG

ORDERING INFORMATION

Fike P/N	Description
10-1430	Abort Switch Assembly
02-2130	Extra Contact Block, N.C.
02-2150	Extra Contact Block, N.O.
02-2137	Abort Adhesive Label
10-104	Stainless Steel Face Plate w/ mounting screws
10-1419	Stainless Steel Face Plate (1)
02-2316	Mounting Screws (4 required)
02-2153	Back Box, 4 x 4, 2 gang, RACO 691



Abort Switch

APPROVALS:

- UL - 3217
- FM
- CSFM - 6760-0900:0103



MOUNTING DIMENSIONS

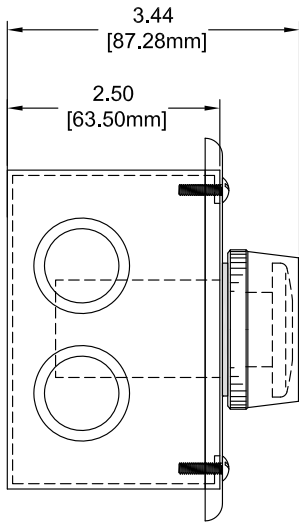

SIDE VIEW W/ ELECTRICAL BOX

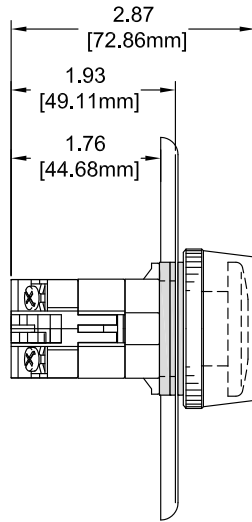

SIDE VIEW W/O ELECTRICAL BOX

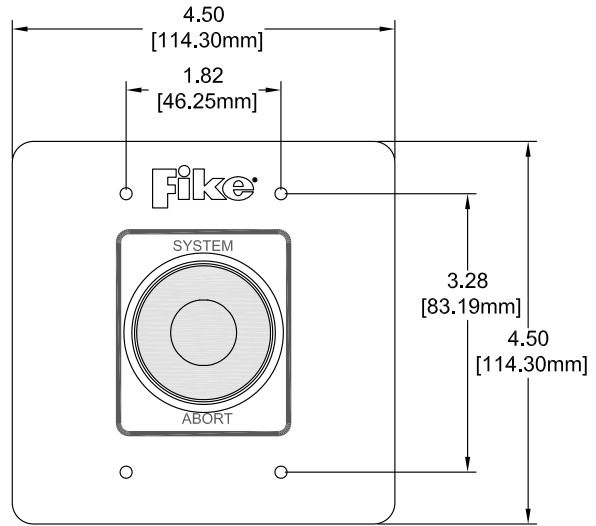

FRONT VIEW

TYPICAL WIRING DIAGRAMS

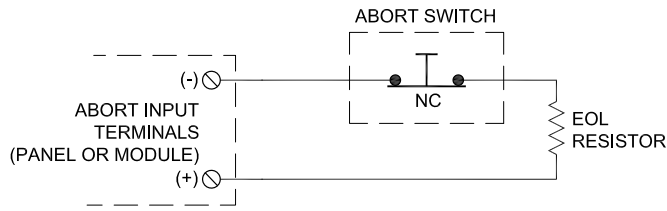

NFPA 72 CLASS B, SERIES WIRING

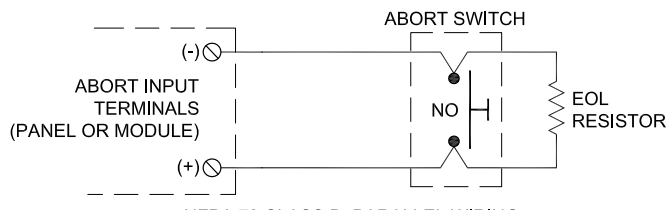

NFPA 72 CLASS B, PARALLEL WIRING

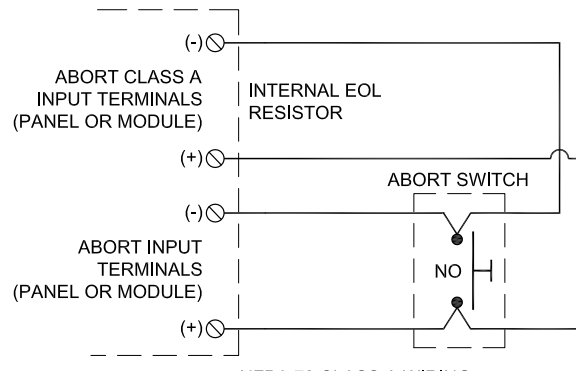

NFPA 72 CLASS A WIRING

SEE CONTROL UNIT MANUAL FOR SPECIFIC WIRING REQUIREMENTS.